

COMPONENT IDENTIFICATION

ITEM	QTY	DESCRIPTION
1	2	CLOSED-OPEN POSITION INDICATORS WITH PADLOCK PROVISIONS
2	2	CLOSE-OPEN POSITION INDICATORS WITH PADLOCK PROVISIONS, PROGRAMMABLE CONTROL BOX, 25 ft. OF CABLE & 3 CT'S FOR EACH RFI WAY
3	1	NAMEPLATE WITH RATINGS AND LINE DIAGRAM
4	1	COLOR CODED PRESSURE GAUGE
5	1	SF6 FILL VALVE (SWITCH FACTORY FILLED AT 10 PSIG)
6	4	2/0 AWG MAXIMUM GROUND LUGS
7	4	REMOVABLE OPERATING HANDLES
8	4	9/16" DIAMETER MOUNTING PROVISIONS FOR SWITCH
9	6	200 AMP DEEPWELL BUSHINGS
10	6	600 AMP BUSHINGS
11	1	304L STAINLESS STEEL SWITCH TANK WITH ASA #70 LIGHT GRAY FINISH
12	12	BUSHING PROTECTIVE SHIPPING CAPS
13	3	PHASE IDENTIFICATION TAGS
14	2	LIFTING EYES
15	2	WINDOW FOR RFI CLOSE-OPEN POSITION INDICATOR
16	2	CAUTION LABEL
17	16	MOTOR OPERATOR PROVISION (STUDS ONLY)
18	12	PARKING STAND
19	2	WINDOWS FOR VISIBLE BREAK AND POSITION INDICATING PLAQUE
20		
21		
22		
23		
24		
25		
26		

RATINGS		SWITCH	RFI	SPECIFICATIONS
MAXIMUM DESIGN VOLTAGE	15.5 kV	15.5 kV		SWITCH PER ANSI C37.71
BIL IMPULSE WITHSTAND	95 kV	95 kV		
AC ONE MINUTE WITHSTAND	35 kV	35 kV		
DC FIFTEEN MINUTE WITHSTAND	66 kV	53 kV		
CORONA EXTINCTION	11 kV	11 kV		BUSHINGS PER ANSI/IEEE 386
OPEN GAP BIL IMPULSE WITHSTAND **	200 kV	95 kV		
LOAD INTERRUPTING AND LOOP SWITCHING	600 A	600 A		
MAGNETIZING CURRENT SWITCHING	25 A	21 A		
CAPACITIVE CURRENT SWITCHING	40 A	25 A		RFI PER APPLICABLE PORTIONS OF ANSI C37.60 AND C37.71
CONTINUOUS CURRENT *	600 A	600 A		
EIGHT HOUR OVERLOAD CURRENT *	900 A	900 A		
ASYMMETRICAL MOMENTARY AND THREE SHOT FAULT CLOSE *	22.5 kA	19.2 kA		
SYMMETRICAL ONE SECOND RATING *	15 kA	12 kA		COMMERCIAL GRADE SF6 GAS PER ASTM D-2472
OVERLOAD INTERRUPTING CAPACITY	3000 A	12 kA		
MECHANICAL LIFE OPERATIONS	2000	2000		
APPLICATION INFORMATION				
CORROSION RESISTANCE PER ASTM-B-117-54 (HOURS)		2000		
MAXIMUM GAS LEAKAGE (cc/SECOND)		10 *		
NORMAL OPERATING PRESSURE RANGE (PSIG)		2 - 15		

* WHEN 200 AMP ELBOWS ARE USED, THE CONTINUOUS CURRENT, OVERLOAD, MOMENTARY AND ONE SECOND RATINGS WILL BE REDUCED. TYPICALLY, 200 AMP ACCESSORIES ARE RATED 200 AMP CONTINUOUS, 300 AMP EIGHT HOUR OVERLOAD, 15 kA ASYMMETRICAL MOMENTARY AND 10 kA SYMMETRICAL FOR 1/2 SECOND.
 ** WITH TANK AND ADJACENT PHASES FLOATING

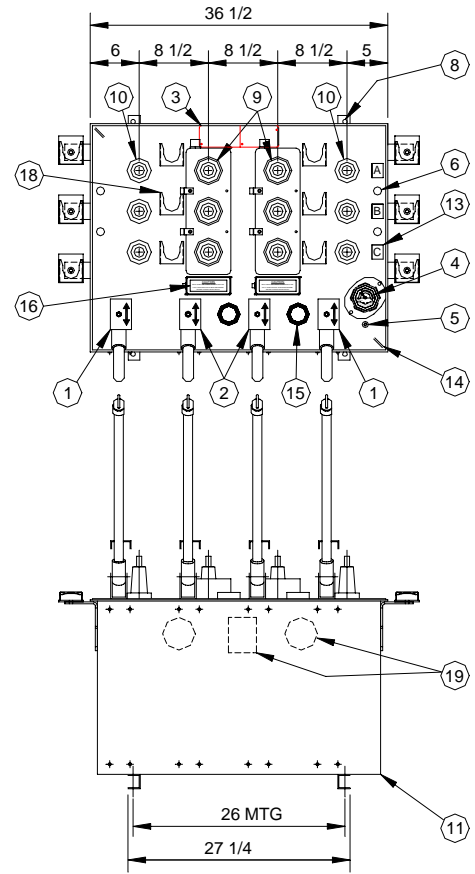

NOTE: ALL DIMENSIONS SHOWN ARE IN INCHES

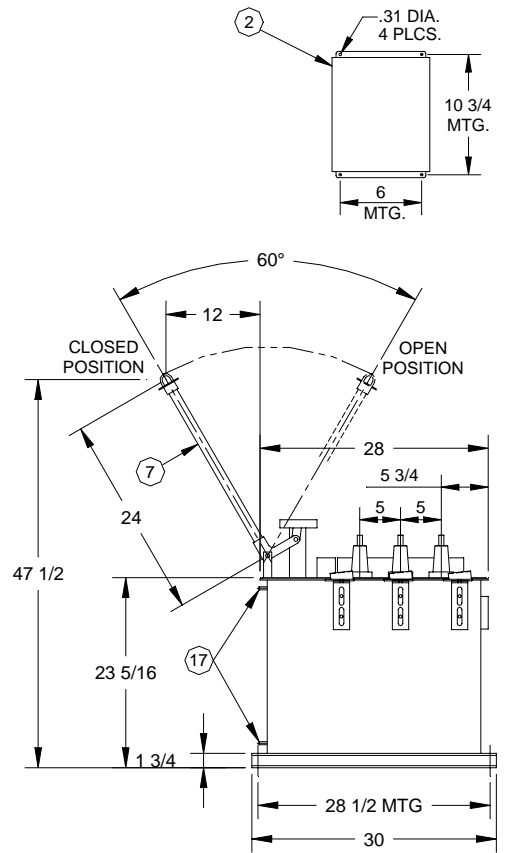

PUFFER PAK® LOAD BREAK SWITCH/RFI

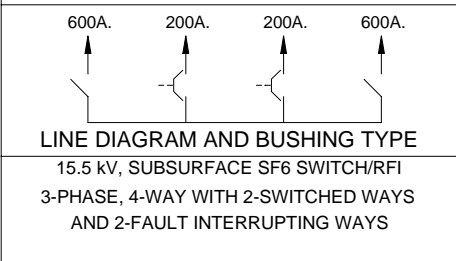

CATALOG NO. SRG6-44-15
 MODEL NO. 6TT6/VB/PS/G70
 WEIGHT : 550 lbs.
 REQ'D. MANHOLE OPENING : 42" DIA.

CANADA POWER PRODUCTS CORP.
 CPP # _____ CUST-6A _____ DATE _____
 REV/ECN # _____ DRAWN _____
 ENGINEER _____ DATE _____
 QUOTE APPROVAL PRODUCTION